

Mitsubishi Tandem Photovoltaic Module

After more than five years of producing reliable and extremely high-quality amorphous silicon photovoltaic modules, MHI has successfully developed and commercialized a new generation of micromorph tandem-type modules with even higher generating capacities.

These tandem modules have a double-layer structure with a microcrystalline silicon film on an amorphous silicon film. The solar absorption spectrum of these modules extends from ultraviolet to visible and infrared wavelengths, assuring the generation of considerably more power than can be expected from the conventional amorphous modules from MHI. The thin-film structure enables the manufacture of the modules with only small amounts of silicon and energy, extending the reduction of CO₂ emissions over conventional crystalline modules.

The next generation of tandem photovoltaic modules from MHI expand the possibilities of clean energy by combining high efficiency with environmental care.

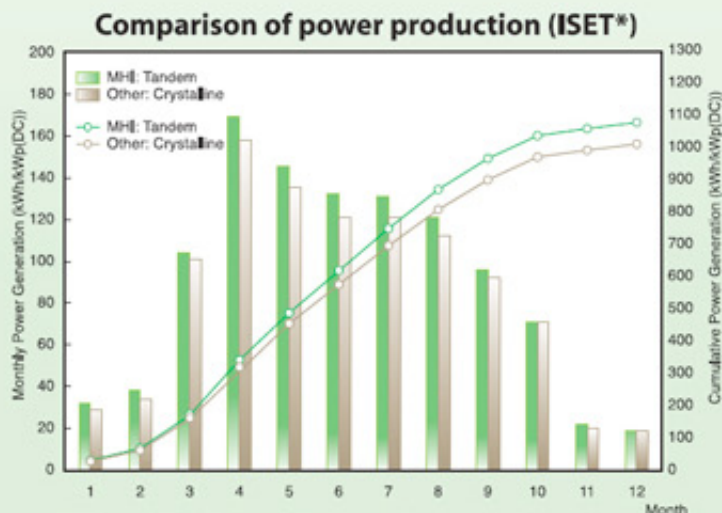

Test period: Jan. ~ Dec, 2007
 * ISET: Institut für Solare Energieversorgungstechnik (Kassel, Germany)



FEATURES

- Higher annual power generation than conventional modules (crystalline silicon type)
 See the field test record by ISET, Kassel, in Germany (left side)
- Generates 1.3 more power (maximum output) than MHI's amorphous silicon photovoltaic type
- Thin films need less silicon to be produced
- Applying lead-free solder and halogen-free cables contribute to environmental conservation

QUALITY & SAFETY

The MT (MHI Tandem) is awarded the following international certifications:

- Manufactured in an ISO 9001 certified factory
- IEC 61646 and IEC 61730 certified

SPECIFICATIONS

Mechanical Characteristics

Model	MT110
Dimensions (Length x Width x Thickness)	1,414 mm x 1,114 mm x 35 mm
Weight	Approx. 21 kg

Electrical Characteristics

Power	110Wp
Voc	131V
Isc	1.3A
Vmp	101V
Imp	1.09A

Temperature Coefficients

Maximum power (W)	-0.28%/°C
Maximum power voltage (V)	-0.33%/°C
Maximum power current (A)	+0.06%/°C
Open circuit voltage (V)	-0.32%/°C
Short circuit current (A)	+0.06%/°C

Measurements made under the standard test conditions (STC):

- Irradiance of 1 kW/m²
- Spectrum of AM1.5
- Module temperature of 25°C

* MHI reserves its rights to change without prior notice the contents of this data.

Appearance

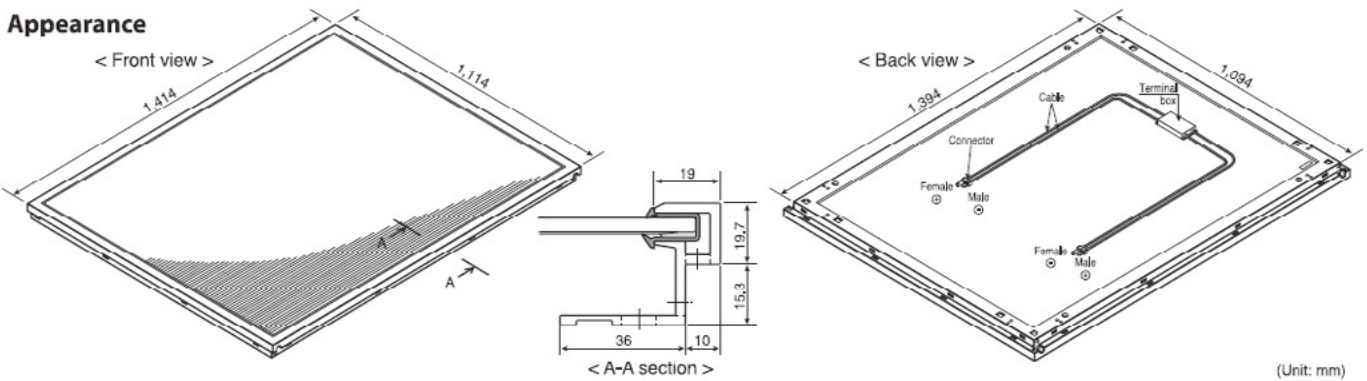

I-V curve in various temperature

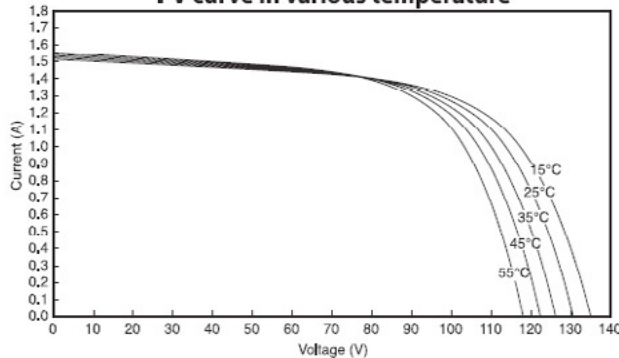

I-V curve in various irradiance

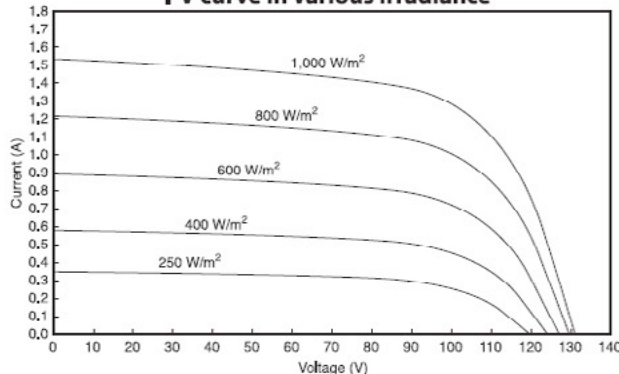

Wiring Principle

Mitsubishi Tandem PV modules connection functional system reduces the need of special cables and connection box, and thus substantially contributes to cost reduction.

(a) Parallel connection

PV modules can be connected in parallel by fastening together adjacent positive cables, and together adjacent negative cables.

(b) Series connection

PV modules can be connected in series by fastening the positive cable of one parallel string and the negative cable of another parallel string.

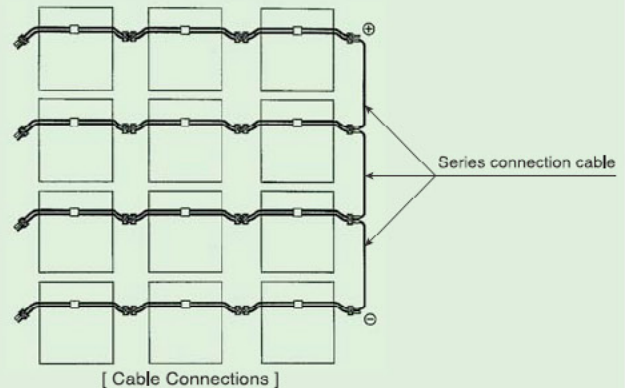

Renewable Energy Business Division

Solar Power System Business Unit

3-1, Minatomirai 3-chome, Nishi-ku, Yokohama 220-8401, Japan

Tel: +81-45-200-7922 Fax: +81-45-200-7738

E-mail for contact: photovoltaic@mhi.co.jp URL: http://www.mhi.co.jp/power/e_a-si

SPECIFICATIONS

Mechanical Characteristics

Model	MT120
Dimensions (Length x Width x Thickness)	1,414 mm x 1,114 mm x 35 mm
Weight	Approx. 21 kg

Electrical Characteristics

Power	120Wp
Voc	131V
Isc	1.42A
Vmp	101V
Imp	1.19A

Temperature Coefficients

Maximum power (W)	-0.28%/°C
Maximum power voltage (V)	-0.33%/°C
Maximum power current (A)	+0.06%/°C
Open circuit voltage (V)	-0.32%/°C
Short circuit current (A)	+0.06%/°C

Measurements made under the standard test conditions (STC):

- Irradiance of 1 kW/m²

- Spectrum of AM1.5

- Module temperature of 25°C

* MHI reserves its rights to change without prior notice the contents of this data.

Appearance

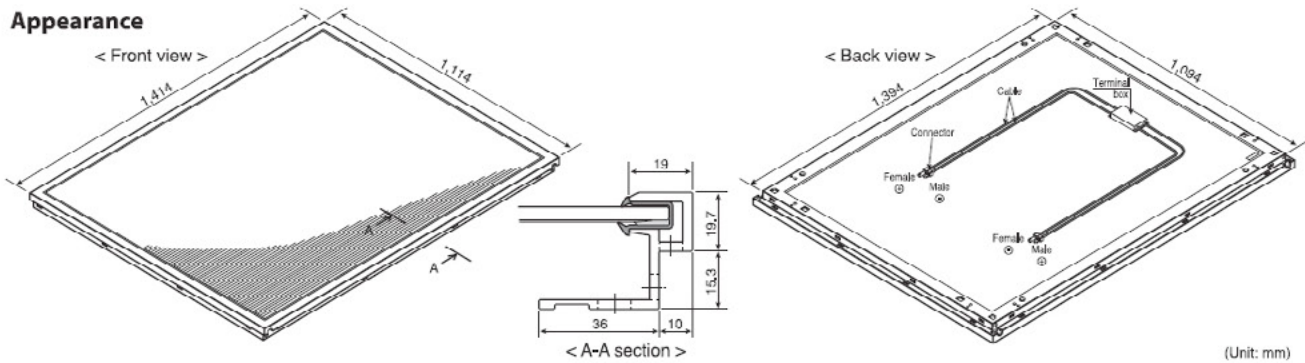

I-V curve in various temperature

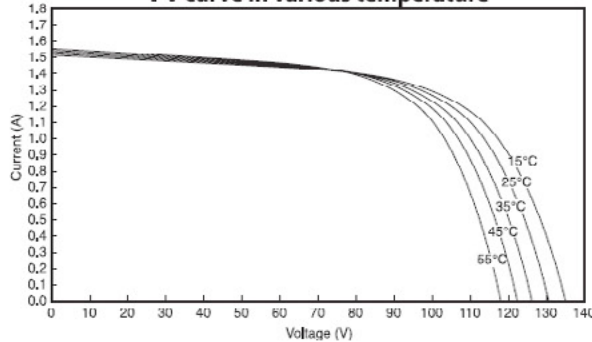

I-V curve in various irradiance

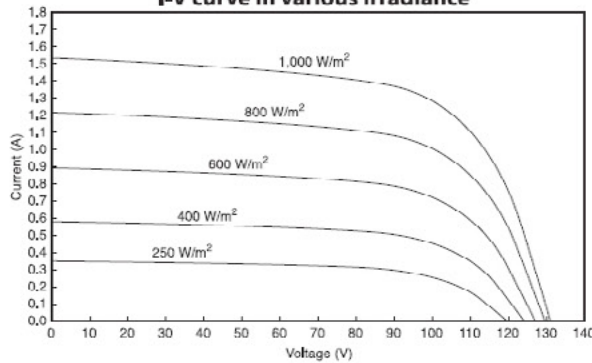

Wiring Principle

Mitsubishi Tandem PV modules connection functional system reduces the need of special cables and connection box, and thus substantially contributes to cost reduction.

(a) Parallel connection

PV modules can be connected in parallel by fastening together adjacent positive cables, and together adjacent negative cables.

(b) Series connection

PV modules can be connected in series by fastening the positive cable of one parallel string and the negative cable of another parallel string.

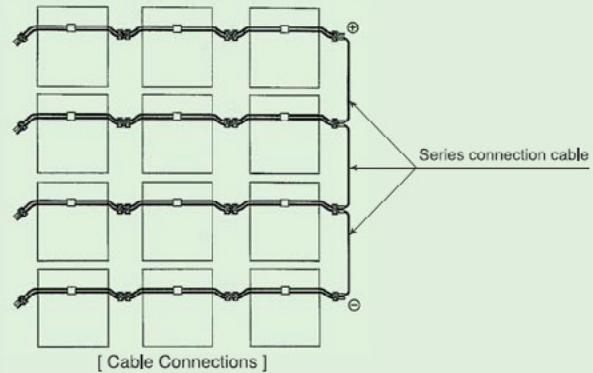

Renewable Energy Business Division

Solar Power System Business Unit

3-1, Minatomirai 3-chome, Nishi-ku, Yokohama 220-8401, Japan

Tel: +81-45-200-7922 Fax: +81-45-200-7738

E-mail for contact: photovoltaic@mhi.co.jp URL: http://www.mhi.co.jp/power/e_a-si

Printed in Japan